

L:
 CBL-HFPD3SAB5MBS-1m 1000mm±20mm
 CBL-HFPD3SAB5MBS-2m 2000mm±20mm
 CBL-HFPD3SAB5MBS-3m 3000mm±20mm

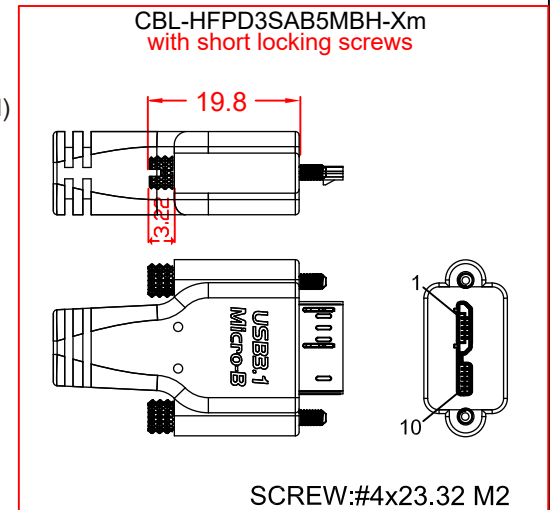

No	MATERIALS LIST:
1.	CABLE: 3 x (2 x 28 AWG)ST + 2 x 26 AWG O.D.:.6.1mm COLOR:RED LILAC
2.	CONNECTOR:USB 3.0 A/M, 9P, BLUE INSULATOR SOLDER TYPE, NICKEL PLATED SHELL
3.	CONNECTOR:USB 3.0 MicroB/M, 10P, BLACK INSULATOR SOLDER TYPE, NICKEL PLATED SHELL
4.	PVC MOLDED HOUSING, BLACK COLOR
5.	SCREW:#4x33 M2

Jargy part no.	Client part no.	Approved	SCALE	UNIT
CBL-HFPD3SAB5MBS-xm				mm
Drawing Name		Drawn	Date	REV.
USB 3.0 A to MicroB Cable M/M				1.0

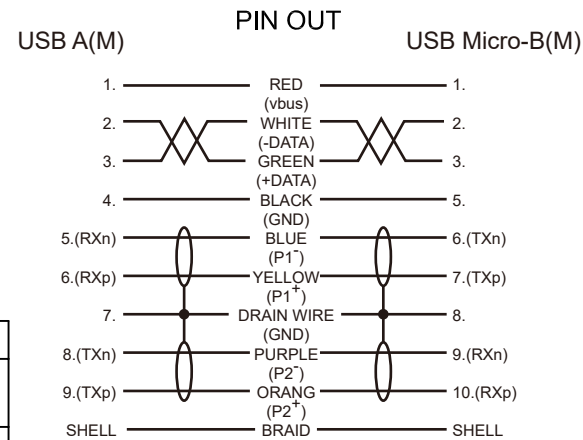
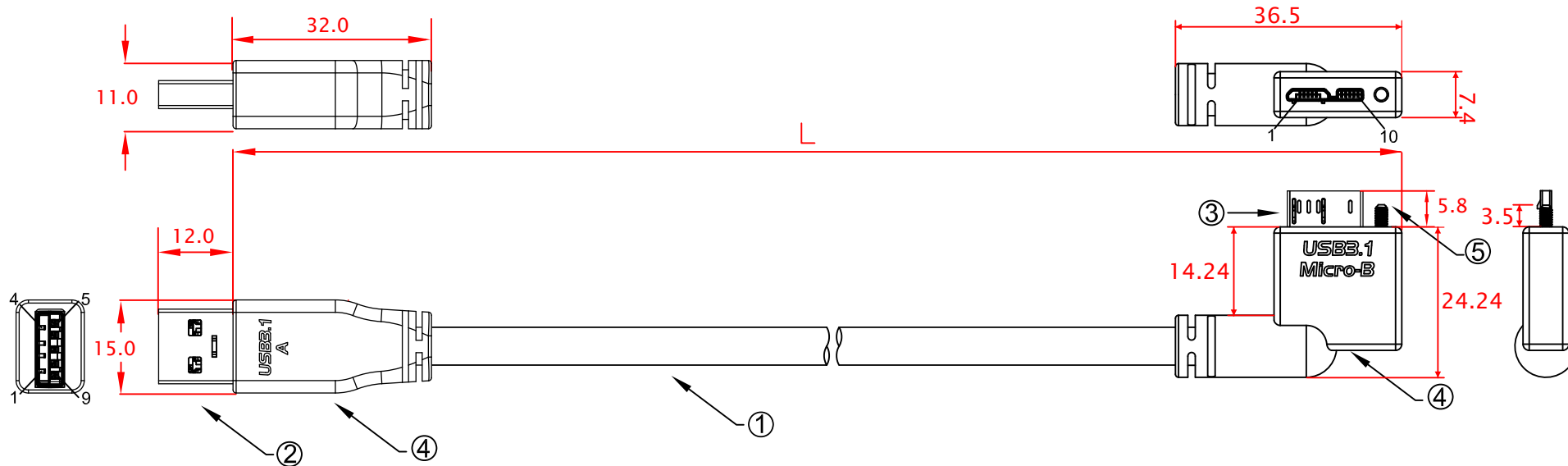

L:
 CBL-HFPD3SAB5MBH-1mLA 1000mm±20mm
 CBL-HFPD3SAB5MBH-2mLA 2000mm±20mm
 CBL-HFPD3SAB5MBH-3mLA 3000mm±20mm

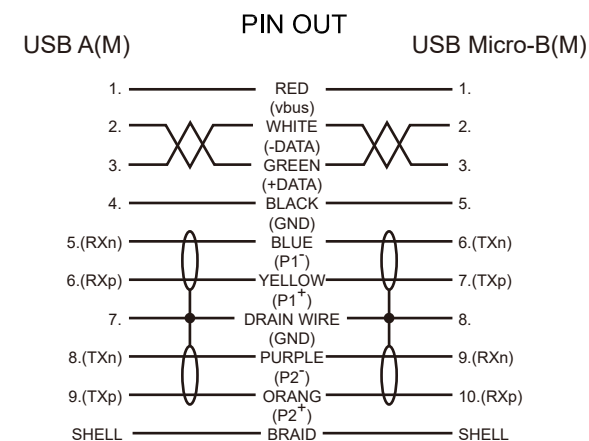

No	MATERIALS LIST:
1.	CABLE: 3 x (2 x 28 AWG)ST + 2 x 26 AWG O.D.:.6.1mm COLOR:RED LILAC
2.	CONNECTOR:USB 3.0 A/M, 9P, BLUE INSULATOR SOLDER TYPE, NICKEL PLATED SHELL
3.	CONNECTOR:USB 3.0 MicroB/M, 10P, BLACK INSULATOR SOLDER TYPE, NICKEL PLATED SHELL
4.	PVC MOLDED HOUSING, BLACK COLOR
5.	SCREW:#4x23.32 M2

Jargy part no.	Client part no.	Approved	SCALE	UNIT
CBL-HFPD3SAB5MBH-xmLA				mm
Drawing Name		Drawn	Date	REV.
USB 3.0 A to MicroB Cable M/M				1.0

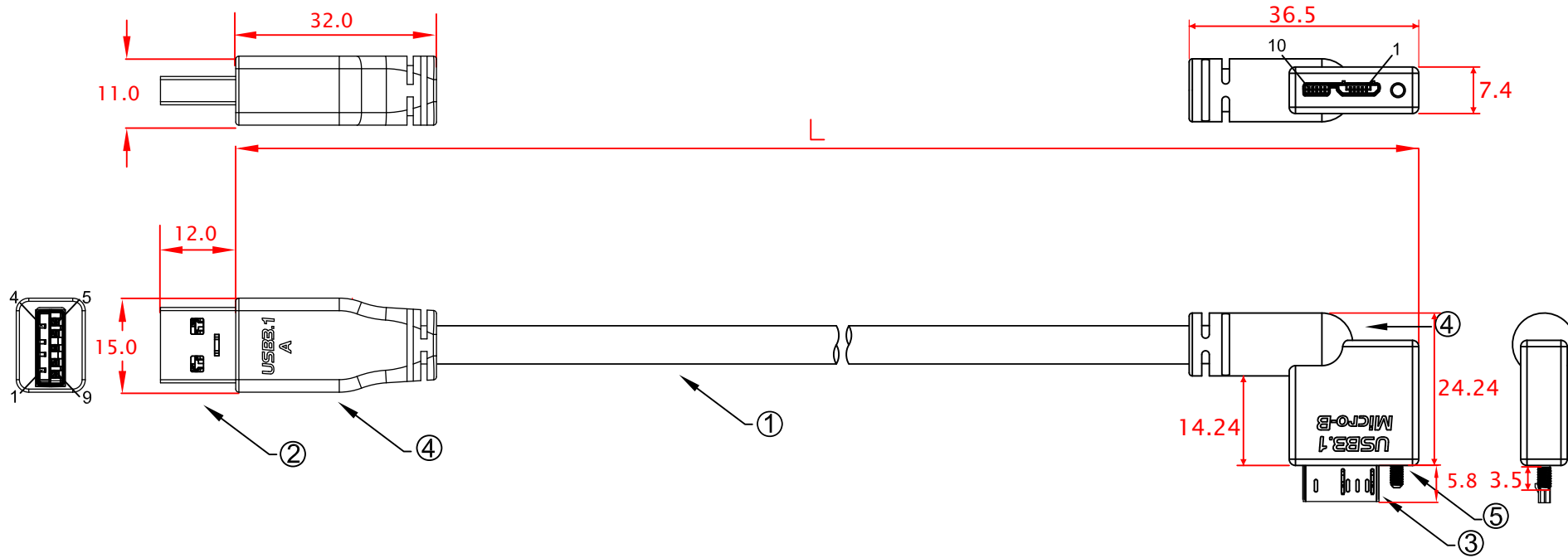

L:
 CBL-HFPD3SAB5MBH-1mRA 1000mm±20mm
 CBL-HFPD3SAB5MBH-2mRA 2000mm±20mm
 CBL-HFPD3SAB5MBH-3mRA 3000mm±20mm

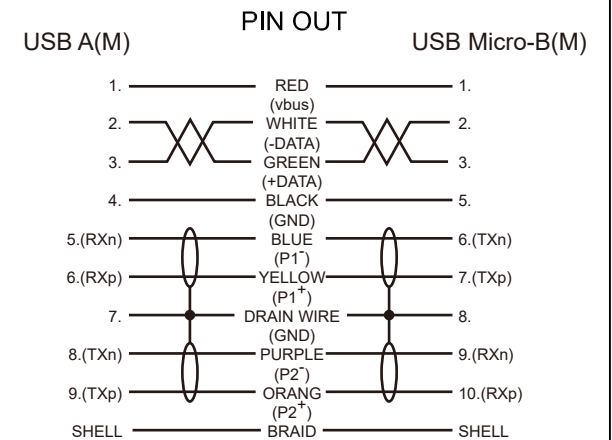

No	MATERIALS LIST:
1.	CABLE: 3 x (2 x 28 AWG)ST + 2 x 26 AWG O.D.:.6.1mm COLOR:RED LILAC
2.	CONNECTOR:USB 3.0 A/M, 9P, BLUE INSULATOR SOLDER TYPE, NICKEL PLATED SHELL
3.	CONNECTOR:USB 3.0 MicroB/M, 10P, BLACK INSULATOR SOLDER TYPE, NICKEL PLATED SHELL
4.	PVC MOLDED HOUSING, BLACK COLOR
5.	SCREW:#4x23.32 M2

Jargy part no.	Client part no.	Approved	SCALE	UNIT
CBL-HFPD3SAB5MBH-xmRA				mm
Drawing Name		Drawn	Date	REV.
USB 3.0 A to MicroB Cable M/M				1.0

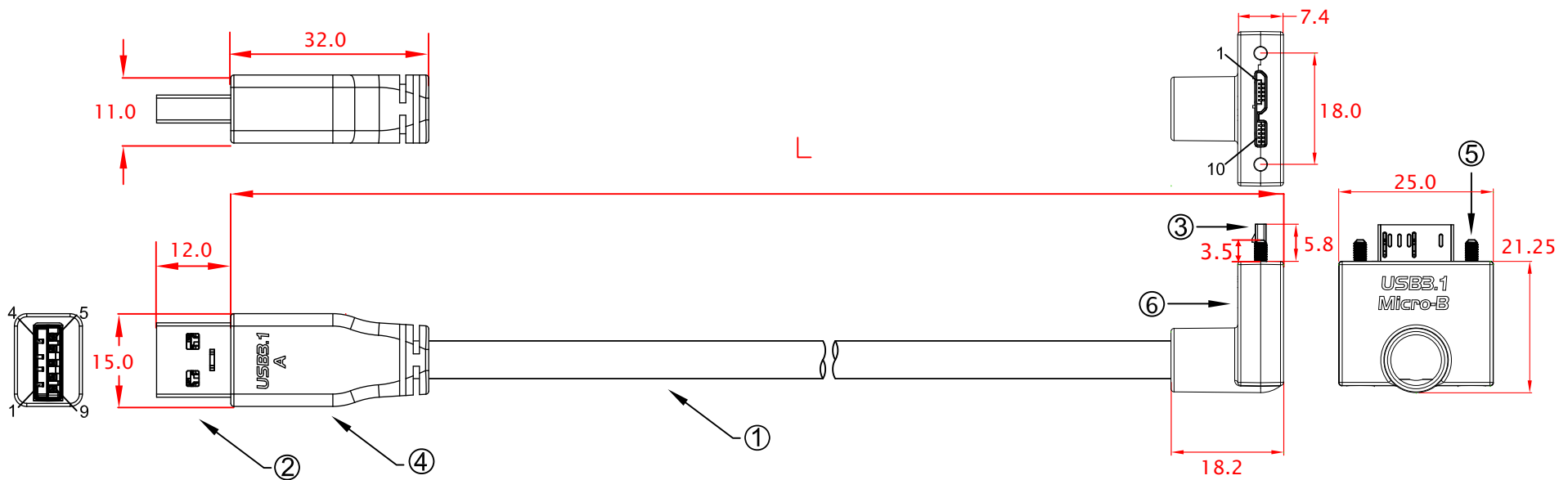

L:
 CBL-HFPD3SAB5MBH-1mUA 1000mm±20mm
 CBL-HFPD3SAB5MBH-2mUA 2000mm±20mm
 CBL-HFPD3SAB5MBH-3mUA 3000mm±20mm

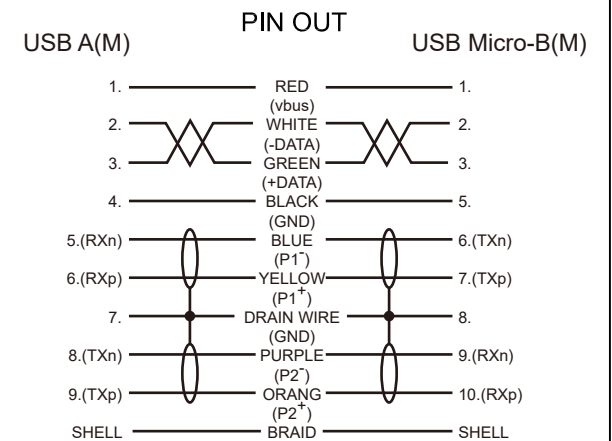

No	MATERIALS LIST:
1.	CABLE: 3 x (2 x 28 AWG)ST + 2 x 26 AWG O.D.:6.1mm COLOR:RED LILAC
2.	CONNECTOR:USB 3.0 A/M, 9P, BLUE INSULATOR SOLDER TYPE, NICKEL PLATED SHELL
3.	CONNECTOR:USB 3.0 MicroB/M, 10P, BLACK INSULATOR SOLDER TYPE, NICKEL PLATED SHELL
4.	PVC MOLDED HOUSING, BLACK COLOR
5.	SCREW:#4x23.32 M2
6.	ABS ASSEMBLY HOUSING, BLACK COLOR

Jargy part no.	Client part no.	Approved	SCALE	UNIT
CBL-HFPD3SAB5MBH-xmUA				mm
Drawing Name		Drawn	Date	REV.
USB 3.0 A to MicroB Cable M/M				1.0

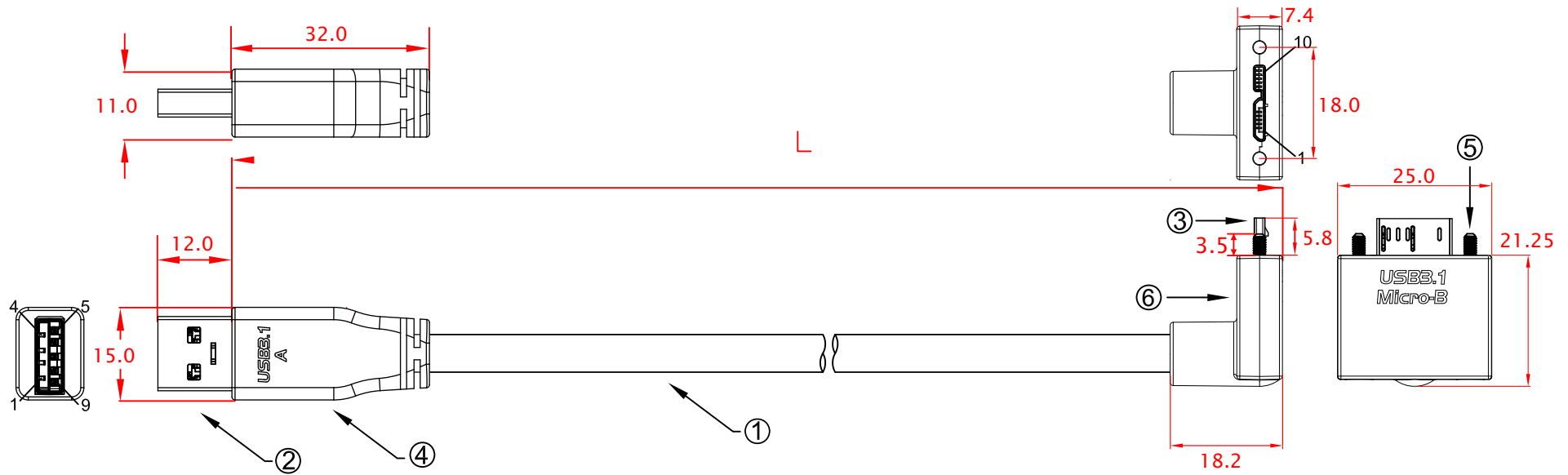

L:
 CBL-HFPD3SAB5MBH-1mDA 1000mm±20mm
 CBL-HFPD3SAB5MBH-2mDA 2000mm±20mm
 CBL-HFPD3SAB5MBH-3mDA 3000mm±20mm

No	MATERIALS LIST:
1.	CABLE: 3 x (2 x 28 AWG)ST + 2 x 26 AWG O.D.:6.1mm COLOR:RED LILAC
2.	CONNECTOR:USB 3.0 A/M, 9P, BLUE INSULATOR SOLDER TYPE, NICKEL PLATED SHELL
3.	CONNECTOR:USB 3.0 MicroB/M, 10P, BLACK INSULATOR SOLDER TYPE, NICKEL PLATED SHELL
4.	PVC MOLDED HOUSING, BLACK COLOR
5.	SCREW:#4x23.32 M2
6.	ABS ASSEMBLY HOUSING, BLACK COLOR

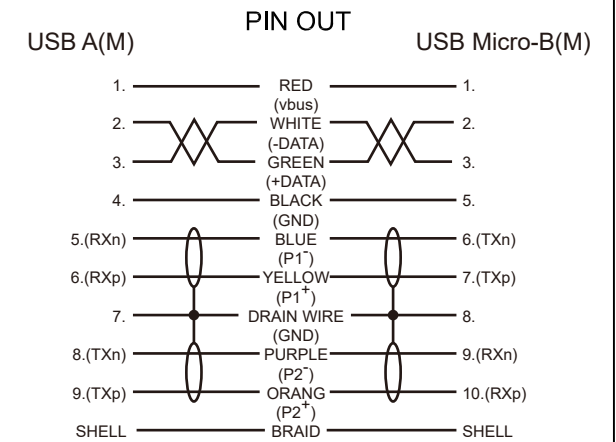

Jargy part no.	Client part no.	Approved	SCALE	UNIT
CBL-HFPD3SAB5MBH-xmDA				mm
Drawing Name		Drawn	Date	REV.
USB 3.0 A to MicroB Cable M/M				1.0